

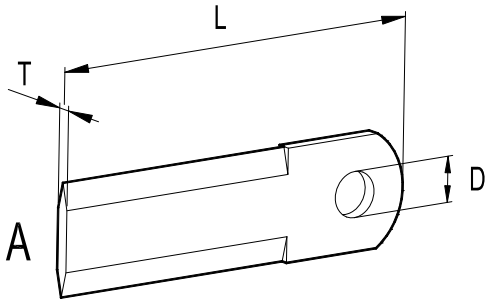

## STRAW CHOPPER KNIVES

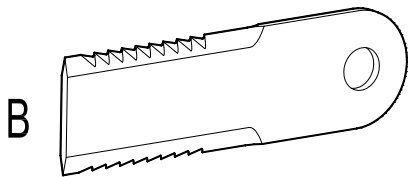

Type	T	L	D	Part no
A	3,0	160	12,5	47823
A	3,5	175	20	Replaced by 41348
A	4,0	173	18	36107
A	5,0	175	20	47646
A	6,35	175	20	36110



B	4,0	173	18	36108
B	5,0	173	20	36109

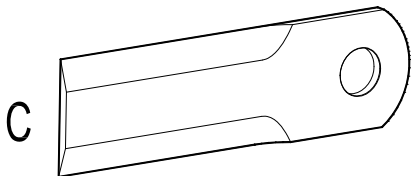

C	3,5	175	20	41348
C	3,5	165	20	42847
C	4,5	175	20	44280

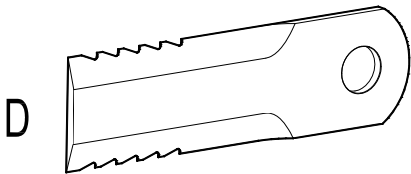

D	4,5	175	20	33770
---	-----	-----	----	-------

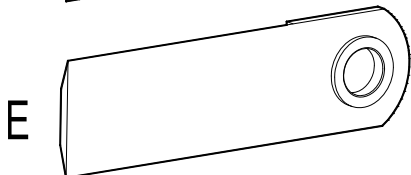

E	4,5	175	20	44443
---	-----	-----	----	-------

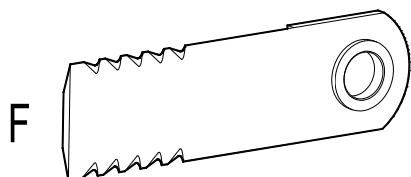

F	4,5	175	20	47011
---	-----	-----	----	-------

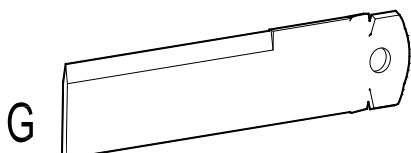

G	3,0	175	10,5	40151
---	-----	-----	------	-------

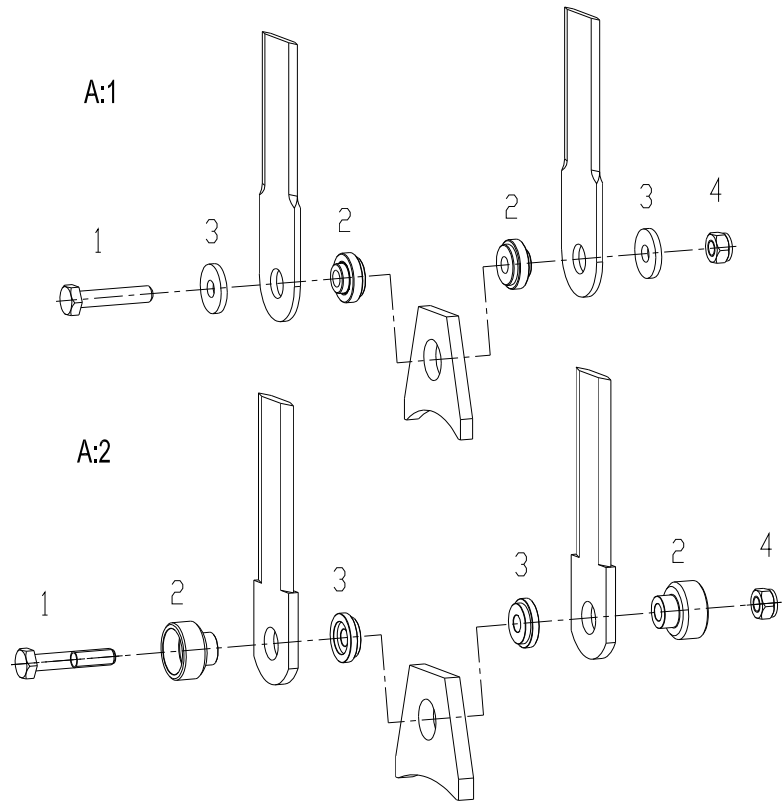

Type	Knife	(1) Screw	(2) Bushing	(3) Spacer / Washer	(4) Nut
A:1	36107	09330	36113	36114	09582
A:2	47646	09461	47647	41349	09582
A:2	36110	09461	47025	41349	09582

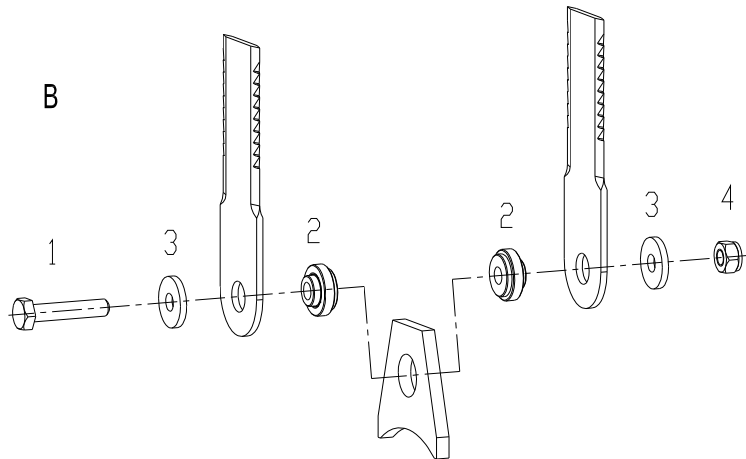

Type	Knife	(1) Screw	(2) Bushing	(3) Spacer / Washer	(4) Nut
B	36108	09330	36113	36114	09582
B	36109	09742	36111	36112	09743

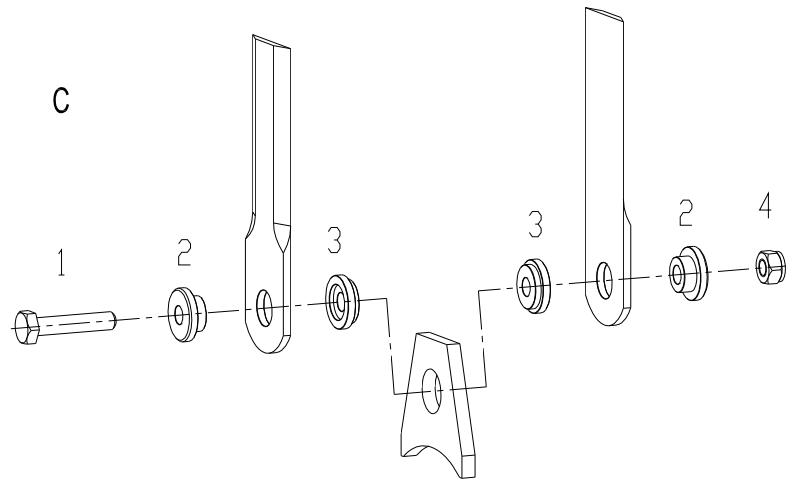

Type	Knife	(1) Screw	(2) Bushing	(3) Spacer / Washer	(4) Nut
C	41348	09330	41350	41349	09582
C	42847	09330	43106	41349	09582
C	44280	09330	44001	41349	09582

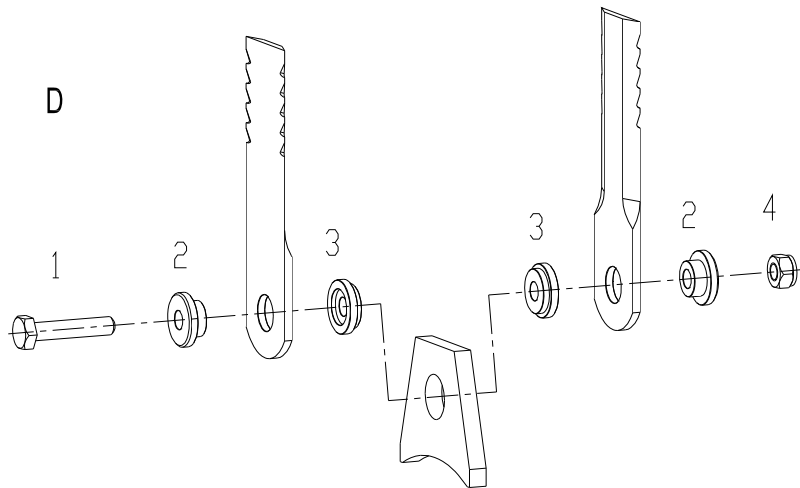

Type	Knife	(1) Screw	(2) Bushing	(3) Spacer / Washer	(4) Nut
D	33770	09330	44001	41349	09582

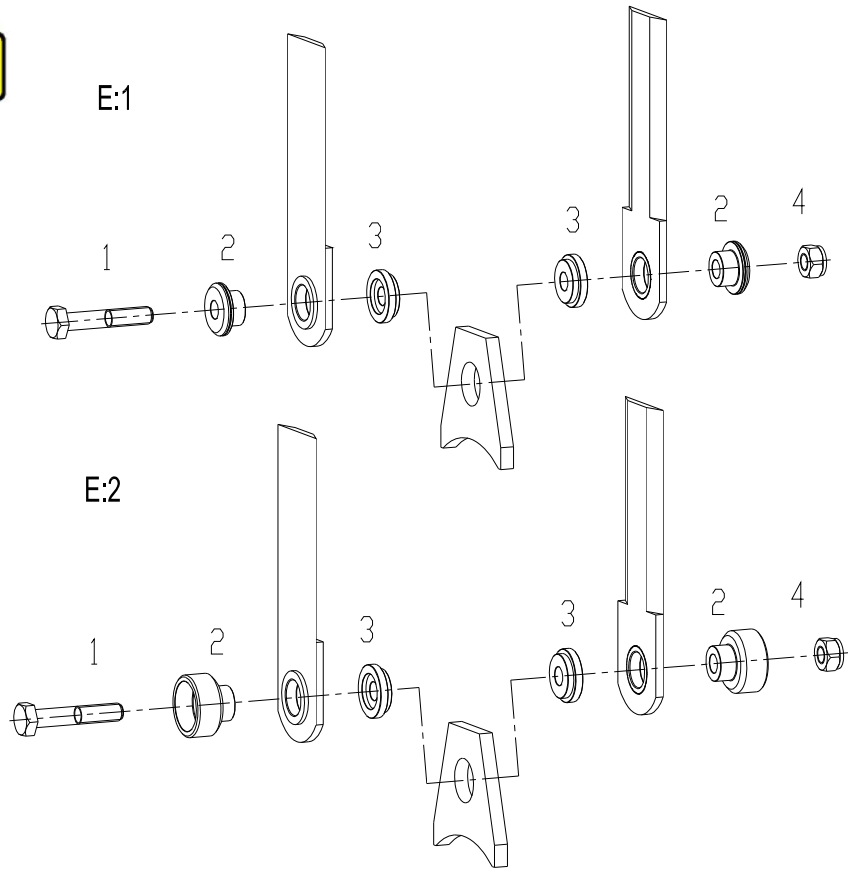

Type	Knife	(1) Screw	(2) Bushing	(3) Spacer / Washer	(4) Nut
E:1	44443	09461	44441	41349	09582
E:2	44443	09461	47025	41349	09582

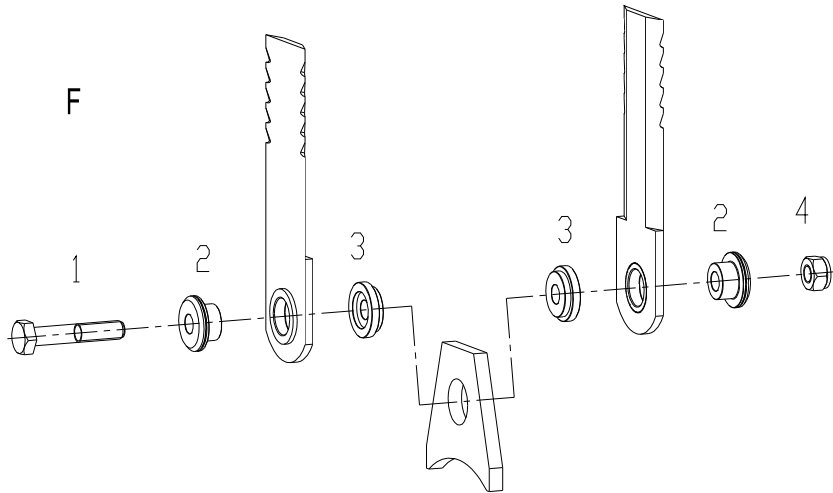

Type	Knife	(1) Screw	(2) Bushing	(3) Spacer / Washer	(4) Nut
F	47011	09461	44441	41349	09582